

Description ADC-II 300 & 600W (eng.)		Doc.no. MA0123	Rev.no. 7
Designed by Håkan Lundh	Approved by Hans Sterner	Page 1 of 22	Date 2001-06-29

ADC-II 300 & 600W

Constant voltage rectifier
Module, 19" and wall-mounted
with options

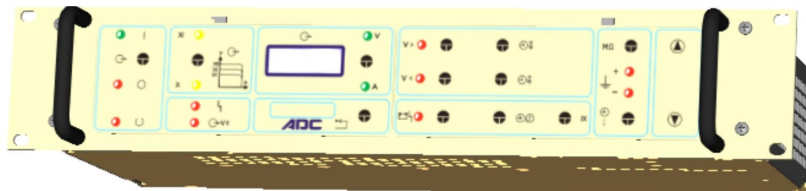
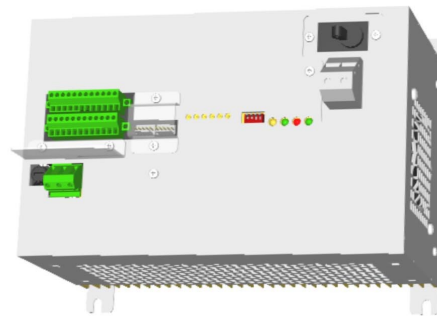
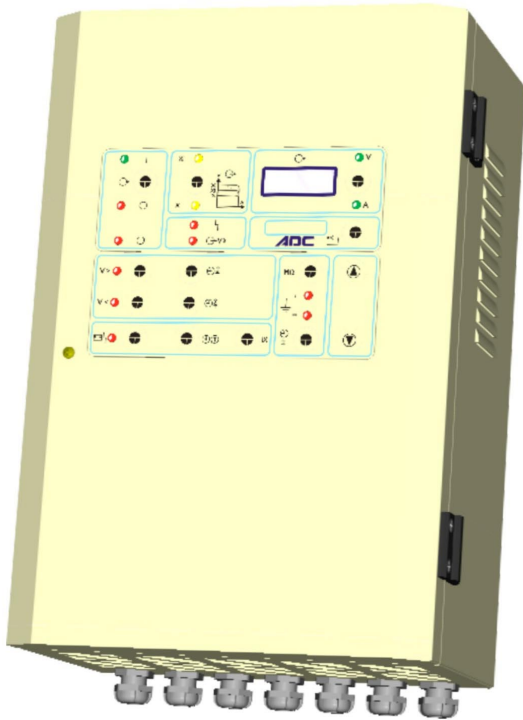

Description ADC-II 300 & 600W (eng.)		Doc.no. MA0123	Rev.no. 7
Designed by Håkan Lundh	Approved by Hans Sterner	Page 2 of 22	Date 2001-06-29

Table of contents

Page

1.	INTRODUCTION _____	4
2.	INSTALLATION _____	5
2.1	MOUNTING _____	5
2.2	TERMINALS _____	5
2.3	ELECTRICAL INSTALLATION _____	6-7
2.4	PARALLEL OPERATION _____	8-9
3.	COMMISSIONING _____	10
3.1	PREPARATION _____	10
3.2	START _____	10
3.3	FLOATING CHARGE _____	10
3.4	BOOST CHARGE _____	10
3.5	CHARGING OF BATTERY _____	10
4.	FUNCTIONS AND ADJUSTMENT _____	11
4.1	CONTROL LEVELS _____	11
4.2	POTENTIOMETER ADJUSTMENT _____	12-13
4.3	SWITCHES _____	14
4.4	INDICATIONS _____	15
5.	MAINTENANCE _____	15
5.1	MAINTENANCE _____	15
6.	CL20 FRONT MONITOR _____	16
6.1	SYMBOLS ON THE FRONT MONITOR _____	16
6.2	FRONT MONITOR ADVANCED FUNCTIONS _____	16
7.	CL30 ALARM MONITOR _____	17
7.1	SYMBOLS ON THE ALARM MONITOR _____	17
7.2	ALARM MONITOR ADVANCED FUNCTIONS _____	17
8.	TROUBLE SHOOTING _____	18
9.	TECHNICAL DATA _____	19-21
10.	DEFAULT SETTINGS _____	22
	CIRCUIT DIAGRAM MODULE _____ 300W _____	3E 10865
	CIRCUIT DIAGRAM 19" _____ 300W _____	3E 10866
	CIRCUIT DIAGRAM WALL _____ 300W _____	3E 10867
	CIRCUIT DIAGRAM MODULE _____ 600W _____	3E 10379
	CIRCUIT DIAGRAM 19" _____ 600W _____	3E 10377
	CIRCUIT DIAGRAM WALL _____ 600W _____	3E 10603

Description ADC-II 300 & 600W (eng.)		Doc.no. MA0123	Rev.no. 7
Designed by Håkan Lundh	Approved by Hans Sterner	Page 3 of 22	Date 2001-06-29

Declaration of Conformity

according to the

Low Voltage Directive, 73/23/EEC, the EMC Directive, 89/336/EEC, including amendments by CE marking Directive, 93/68/EEC.

Type of equipment: Single phase switched AC/DC rectifier 300 and 600W. Sinewave input current with PFC mounted in a metal module, 19" or wall cabinet together with option boards.

Type designation /models: ADC-II 12/20, 24/12(15), 48/6(7.5) and 60/4.8(6) 300W and 24/20, 48/12(15), 60/9.5(12) and 110/5(6.4) 600W module, 19" or wall type.
Options: CL20, CL30 or CL40 and fuse alarm and battery protection

Manufacturer: ELDACO AB, Box 990, 191 29 Sollentuna, Sweden
tel. no: 08-623 95 00, fax 08-96 97 72

The following harmonized European standards or technical specifications have been applied:

LVD:

EN 60 950:1992,A1, A2: 1993; A3: 1995 Electrical safety - IT equipment

EMC:

EN 61000-3-2:1995 Harmonic current emissions

24-60VDC:

EN 50081-1:1992 Generic emission standard - Part 1: Residential, commercial and light industry

EN 50082-2:1995 Generic immunity standard - Part 2: Industrial environment

110VDC:

EN 50081-2:1993 Generic emission standard - Part 2: Industrial environment

EN 50082-2:1995 Generic immunity standard - Part 2: Industrial environment

Additional information

LVD:

- The products complies with the European safety standard listed above.
- We have an internal production control system that ensures compliance between the manufactured products and the technical documentation.

EMC:

- The wall and 19" complies with the harmonized European EMC standards listed.
- The module comply with the EMC standards, but is only CE marked according to the LVD.

As manufacturer, we declare under our sole responsibility that the equipment follows the provisions of Directives stated above.

1999-11-11

Manufacturer



Gunnar Wallebom
Managing Director

Description ADC-II 300 & 600W (eng.)		Doc.no. MA0123	Rev.no. 7
Designed by Håkan Lundh	Approved by Hans Sterner	Page 4 of 22	Date 2001-06-29

1. Introduction

The ADC 300 and 600W rectifiers are a range of AC/DC switch mode rectifiers from 12 to 110V DC in different versions as module, wall-mounted and 19" types. The use is mostly battery charging with temperature compensated voltage or direct DC power supply. The output is constant power limited with three voltage levels and a maximum current limit. In the wall-mounted type a module is placed inside the cabinet. The unit has a fan, temperature controlled and supervised by maximum temperature on the cooler.

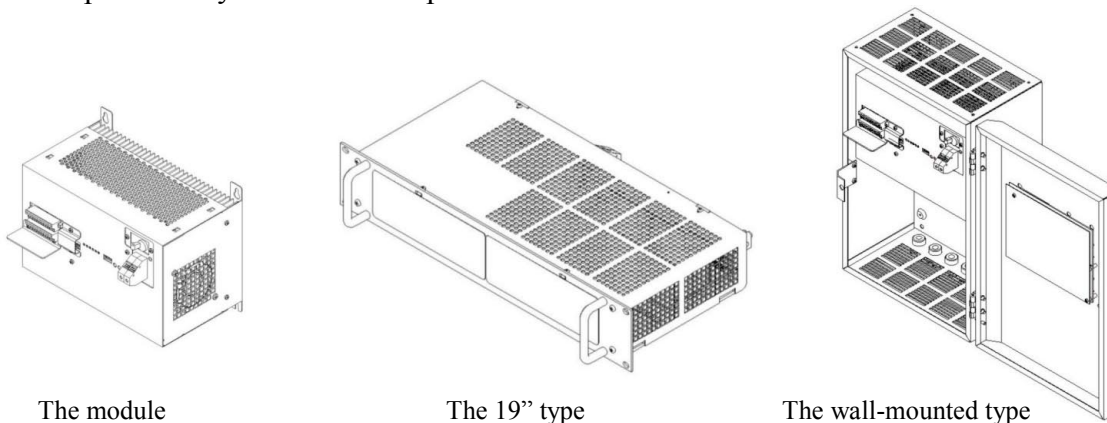

Figure 1. The versions.

The rectifiers are all equipped with "Power Factor Corrector" circuitry on the input to achieve a power factor close to 1. They are also equipped with fuses on both at mains input and DC output. The basic module monitoring is only equipped with LEDs and internal relay alarm outputs.

Optional boards and monitors are operated from the controller- and DC/DC-boards internally in the rectifier:

- **CL20**
Front monitor (functions ON/OFF, boost, display, LEDs and reset).
- **CL30**
Front monitor
Alarm monitor (alarms high/low voltage, adjustable manual and automatic battery circuit test and earth fault +/-).
- **CL40**
Front monitor
Alarm monitor
Relay board (five separate relays common, alarms high/low, battery circuit and earth fault +/-).

The rectifiers can also be equipped with:

- Deep discharge protection circuit to protect the battery against low cell voltage.
 - Distribution outputs with zero voltage alarm.
- The rectifiers can also be connected in parallel with passive current load sharing.

Description ADC-II 300 & 600W (eng.)		Doc.no. MA0123	Rev.no. 7
Designed by Håkan Lundh	Approved by Hans Sterner	Page 5 of 22	Date 2001-06-29

2. Installation

2.1 Mounting

The rectifier must only be installed by experienced and qualified personnel, as dangerous voltages at both primary and secondary side may occur in the rectifier. Make sure that no heat radiant units are mounted close to the rectifier and that free circulation of cooling air is available.

Before connecting the rectifier, carry out the following:

1. Check the outside and inside (wall-mounted type) of the rectifier to make sure that there are no transportation damages.
2. Check that the line- and battery voltage corresponds to the type label of the rectifier.

The module and 19" rectifier must be mounted inside a cabinet to protect the users from dangerous high voltages and temperatures.

The wall-mounted rectifier has it's own cabinet, ready for use.

2.2 Terminals

The rectifier is equipped with a mains input, DC-output and signal terminals, located as follows:

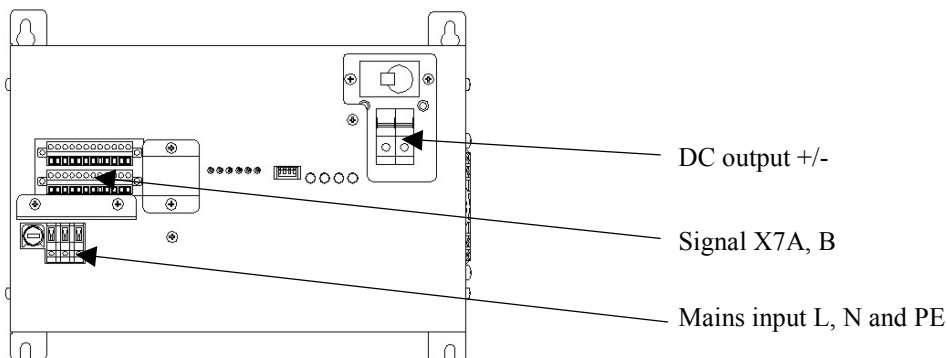

Figure 2. The module and wall-mounted module front side.

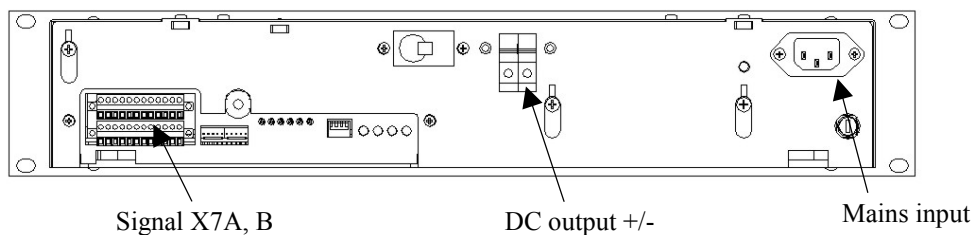

Figure 3. The 19" rear side.

Description ADC-II 300 & 600W (eng.)		Doc.no. MA0123	Rev.no. 7
Designed by Håkan Lundh	Approved by Hans Sterner	Page 6 of 22	Date 2001-06-29

2.3 Electrical installation

2.3.1 Mains:

Module and wall-mounted type: Connect the mains cable to the terminal signed L, N, PE directly on the front on the module. An appropriate disconnect device for the mains shall be provided as a part of the installation to secure a fast disconnecting of the mains.

19" unit: Connect the plug-in mains cable at the rear of the unit.

Recommended mains fuse is 300W 6AT and 600W 10AT.

Important: Always connect the PE terminal for safety protection.

2.3.2 Load:

Check that the battery- and load fuses are removed. Connect the load (battery) to the rectifier output terminal signed +/-.

2.3.3 Signals:

X7A:

X7A:1-2 Remote inhibit of boost voltage level input. By closing this input, with a potential free contact or shorting cable, the module is allowed to activate boost voltage level.

X7A:3-4 Battery temperature sensor input By connecting a 2k Ω PTC type KTY 81-210 to this input and S1:1=UP, the module floating voltage level will be battery temperature compensated.

X7A:5-7 Common alarm relay potential free output. All alarms also optional alarm board and mains fault, are connected to this output.



X7A:8-10 Mains fault alarm relay potential free output. Alarm is given at low mains input.



X7A:12 Earth sense input. By connecting this input directly to chassis the earth fault +/- alarm on the optional alarm board CL30 and 40 is activated. On rectifiers delivered with option CL30 or CL40 this input is already connected to chassis.

Description ADC-II 300 & 600W (eng.)		Doc.no. MA0123	Rev.no. 7
Designed by Håkan Lundh	Approved by Hans Sterner	Page 7 of 22	Date 2001-06-29

2.3.3 Signals cont.:

X7B:

- X7B:1-2 Remote inhibit operation ON/OFF input. By closing this input, with a potential free contact, the module operation stops and no power are delivered to the output.
- X7B:3-4 Remote Boost ON/OFF. By closing this input, with a potential free contact, the module leaves floating voltage level and raises the output voltage to the boost level. No time limit.
- X7B:5-6 Remote Battery circuit test ON/OFF. By closing this input, with a potential free contact, the module leaves floating or boost voltage level and decreases the output voltage to the battery circuit test level. No time limit.
- X7B:7-8 Battery circuit test potential free output to next rectifier in parallel systems.
- X7B:9-10 Boost level potential free output to next rectifier in parallel systems.
- X7B:11-12 External supply 9-12V (0V on 12) output. Max load depending on options on the I²C bus. See “technical data”

2.3.4 Relay-board (Option CL40):

X1:1-3: Battery circuit test fault

X1:4-6: High charging voltage

X1:7-9: Low charging voltage 3, 6, 9, 12, 15

X1:10-12: Earth fault 1, 4, 7, 10, 13

X1:13-15: Common alarm 2, 5, 8, 11, 14



Alarm position

Mains is not allowed to be mixed with DC-output on the relay terminals.

2.3.5 I²C bus

The I²C bus connectors **X9** and **X9.1** are used when controller option is used to communicate with external I²C bus boards in the system. All I²C bus connectors has the same pinning to be able to connect the special I²C bus cable in any position. The standard length of the I²C bus cable is 350mm or 700mm. It's not allowed to route the I²C bus cable outside the cabinet.

Description ADC-II 300 & 600W (eng.)		Doc.no. MA0123	Rev.no. 7
Designed by Håkan Lundh	Approved by Hans Sterner	Page 8 of 22	Date 2001-06-29

2.4 Parallel operation

2.4.1 Function

The rectifiers can be connected in parallel with passive load current sharing with or without options in a master-slave configuration. To get a good current sharing the rectifiers must be connected as intended in figure 4. Observe the signals for boost and battery test operating.

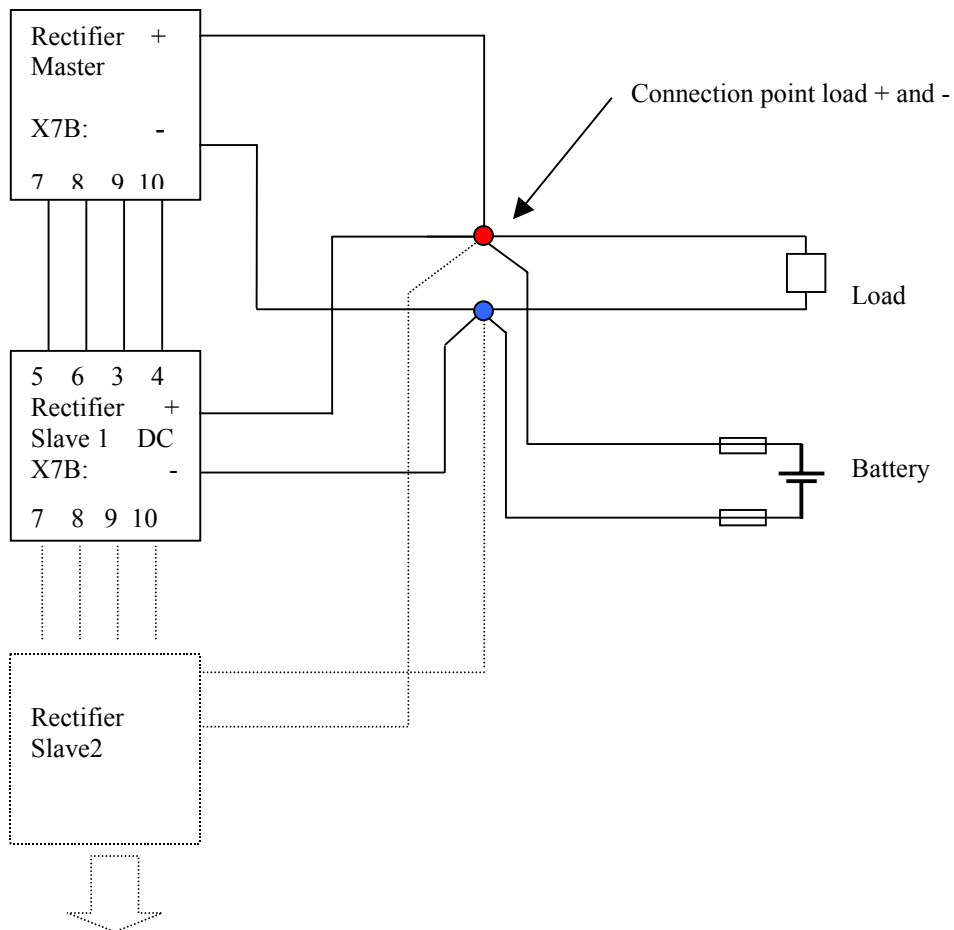

Figure 4. Parallel operation connection.

Description ADC-II 300 & 600W (eng.)		Doc.no. MA0123	Rev.no. 7
Designed by Håkan Lundh	Approved by Hans Sterner	Page 9 of 22	Date 2001-06-29

Important :

1. The wires to the connection points from each rectifier must have the same voltage drop and resistance (same length, area...).
2. The battery temperature sensor (if temperature compensation is used) must be connected to each rectifier.
3. If boost level is permanently inhibited the connection from the master X7B:9, 10 to the slave X7B:3, 4 is not needed.
4. If battery circuit test is permanently inhibited the connection from the master X7B:7, 8 to the slave X7B:5, 6 is not needed.
5. The alarm relay outputs can be serial connected to get one alarm from the system.

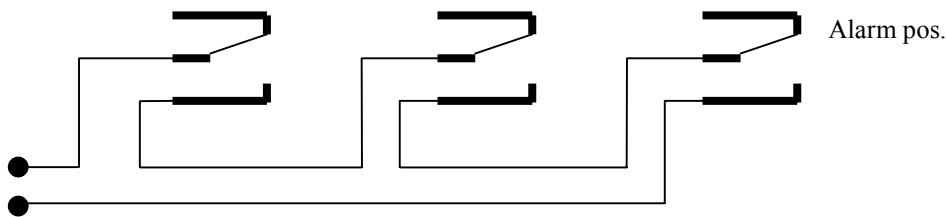

Figure 5. Serial connected alarm relays.

6. The earth fault option CL30-40 alarm sense input X7A:12 must be disconnected in the slaves to avoid wrong measured earth fault resistance.
7. Boost or battery circuit test shall be executed on the master. Otherwise the slaves don't switch to boost or battery circuit test mode. If you set a slave 1 in figure 4 to boost or battery circuit test mode, only the slave 2 and the one's after this will be changed to this mode.

2.4.2 Adjustment

In parallel rectifier systems all rectifiers must be adjusted to the same voltage level in floating, boost and battery circuit test to achieve good current sharing, but adjust the voltage drop compensation first.

The **voltage drop compensation** must be adjusted to -0.2% voltage drop at 0-95% load step, measured at connection point. (Adjustment see 4.2.5).

Description ADC-II 300 & 600W (eng.)		Doc.no. MA0123	Rev.no. 7
Designed by Håkan Lundh	Approved by Hans Sterner	Page 10 of 22	Date 2001-06-29

3. Commissioning

3.1 Preparation

Check all connections to the rectifier. Check that the battery and load fuses are removed or OFF.

3.2 Start

Apply mains power to the rectifier, it will start directly. If front monitor option \geq CL20 is installed, press push button on the front to ON position if OFF LED is lit.

3.3 Floating charge

Check that the output voltage for floating charge, measured at output terminals of the rectifier with the battery temperature sensor inhibited (\rightarrow S1=down and sensor removed), corresponds with the battery supplier recommendations. Adjust according to section 4.2.1 "XI Floating voltage" or with front panel option section 6.2.4 "Adjusting levels for...".

If open lead-acid cells are used:

3.4 Boost charge

Check that boost inhibit input X7A:1, 2 is shorted. Without front panel start boost charge by short X7B:3-4. With front panel start boost charge by pressing boost button on the front panel CL20.

Check the level for boost charge, measure at the output terminals and check that the level corresponds with the battery supplier recommendations. Adjust according to section 4.2.2 "XII Boost voltage" or with front panel option section 6.2.4 "Adjusting levels for...".

If the rectifier has a front monitor option check also the time adjustment for manual and automatic boost. Return to floating charge.

3.5 Charging of battery

Connect the fuses or switch "ON" the circuit breakers to the load and battery. The current increases towards power limit (if the battery is discharged) and the voltage level increases slowly towards the floating charge level. If the "Incorrect charging voltage" is activated an alarm is given until the voltage level is above -2% of adjusted floating charge level with temperature compensation.

When the battery has reached the adjusted floating charge level, the rectifier leaves power limit and the current starts to decline when the voltage level is steady.

If the battery consists of open lead-acid cells, push the start button for boost charge on the front panel if this option is present. The output power increases to the limit and the output voltage increases slowly toward the boost charge level.

Return to floating charge with front panel push button or wait until the rectifier returns to floating charge automatic after adjusted boost charge time.

Description ADC-II 300 & 600W (eng.)		Doc.no. MA0123	Rev.no. 7
Designed by Håkan Lundh	Approved by Hans Sterner	Page 11 of 22	Date 2001-06-29

4. Functions and adjustment

4.1 Functions and control levels

The rectifier has three adjustable voltage levels **floating, boost and battery test level** and a **current limit**. The floating level can be battery temperature compensated if a sensor is connected to the rectifier. The rectifier has internal protection circuitry for over voltage on the DC output with a **shut down level** at activated alarm.

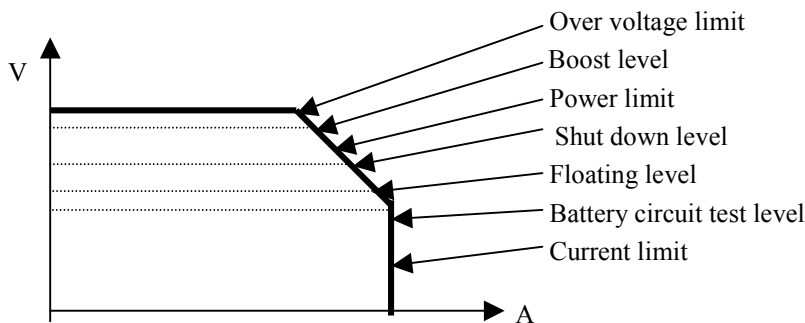

Figure 6. DC output characteristics.

In the optional alarm CL30 both automatic and manual battery circuit test are included and adjustable from the front monitor.

An **voltage drop compensation** is added to achieve correct voltage over the batteries at high load. All levels are preadjusted from factory and doesn't normally need to be adjusted. The rectifier has also internal alarms connected both to the front indication and common alarm relay.

The rectifier module is cooled by a temperature linear controlled fan. Starting at 50-55°C on the cooler and increases speed up to maximum at 70-75°C. At 85°C on the cooler the rectifier decreases the output power and an rectifier alarm is given. At normal room temperature, up 50% load, the natural convection is enough and the fan is normally not running, to achieve a long life time.

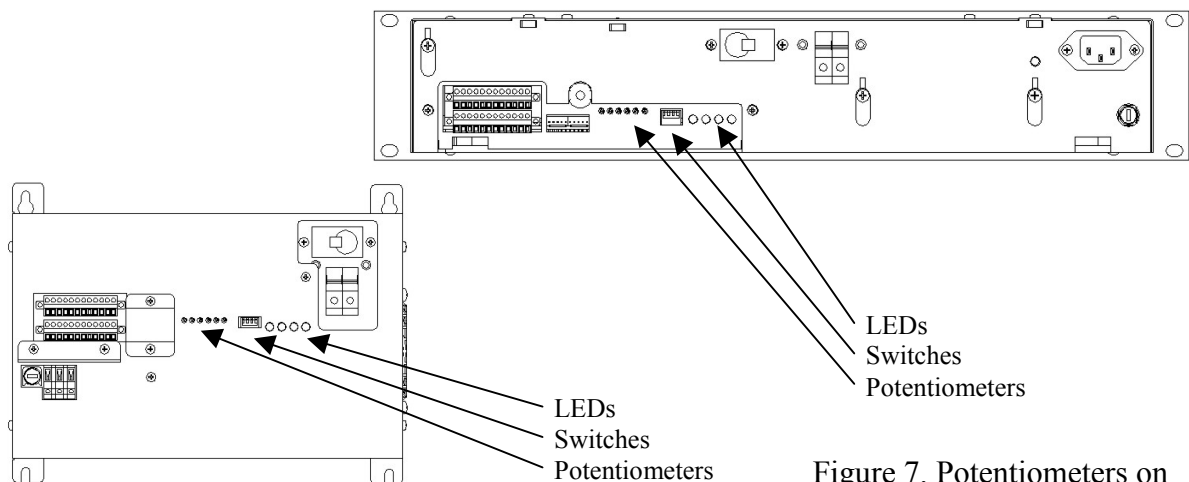

Figure 7. Potentiometers on module and 19''.

Description ADC-II 300 & 600W (eng.)		Doc.no. MA0123	Rev.no. 7
Designed by Håkan Lundh	Approved by Hans Sterner	Page 12 of 22	Date 2001-06-29

4.2 Potentiometer adjustment

4.2.1 XI Floating voltage

Normal floating charge voltage level. Temperature compensated if S1:1 is UP. Effected by the voltage drop compensation and front board option \geq CL20 adjustment.

Adjustment:

- Ensure that voltage drop compensation is adjusted, see section 4.2.5 "Voltage drop compensation".
- Ensure normal load (not current or power limit).
- If temperature sensor connected: Remove X7:A connector and put S1:1 in position DOWN
- Measure with voltmeter accuracy better then 0.1% at the rectifier DC output terminals.
- No option \geq CL20, adjust to correct value with potentiometer XI. Restore the rectifier.
- If front board option \geq CL20 is connected, adjust the boost level on the front board. See section 6.2.4 "Adjusting levels for ...". Restore the rectifier.

4.2.2 XII Boost voltage

Boost charge voltage level and is not temperature compensated. Effected by the voltage drop compensation and front board option \geq CL20 adjustment.

Adjustment:

- Ensure that voltage drop compensation is adjusted, see section 4.2.5 "Voltage drop compensation".
- Activate boost level and ensure normal load (not current or power limit).
- Measure with voltmeter accuracy better then 0.1% at the rectifier DC output terminals.
- No option \geq CL20, adjust to correct value with potentiometer XII. Restore the rectifier.
- If front board option \geq CL20 is connected, adjust the boost level on the front board. See section 6.2.4 "Adjusting levels for ...". Restore the rectifier.

4.2.3 IX Battery circuit test level

This voltage level is used to be able to test the battery by reducing the rectifier output to a low level and meanwhile check if the battery voltage is higher than the battery circuit test alarm level, set on the CL30 or CL40 optional alarm monitor. The alarm is given direct with no time delay. Not temperature compensated. Effected by the voltage drop compensation and front board option adjustment.

Description ADC-II 300 & 600W (eng.)		Doc.no. MA0123	Rev.no. 7
Designed by Håkan Lundh	Approved by Hans Sterner	Page 13 of 22	Date 2001-06-29

Adjustment:

- Ensure that voltage drop compensation is adjusted, see section 4.2.5 "Voltage drop compensation".
- Ensure normal load (not current or power limit).
- Disconnect the battery.
- Measure with voltmeter accuracy better than 0.1% at the rectifier DC output terminals.
- Adjust the battery circuit test level on the alarm board. See section 7.2.5 "CL30 Alarm monitor (option)". Restore the rectifier.

4.2.4 A Current limit

This current limit is used to limit the output current at extreme high loads.

Adjustment:

- Disconnect the battery.
- Load the rectifier to current limit $\ll 1.8V/cell$.
- Measure with amperemeter accuracy better than 0.1% at the rectifier DC output terminal + or - and adjust to correct value. Restore the rectifier.

4.2.5 Voltage drop compensation

Adjustment:

- Disconnect the battery.
- Toggle the load between 0% and 90% at floating level and measure the voltage at the compensation point (rectifier output, battery or load). Adjust to correct value. Default value is -0.2%. Connect the battery.

4.2.6 V> Shut down level

The rectifier has an over voltage protection circuit on the DC output. If this circuit acts, at first the voltage on the rectifier is limited and after 1-2s controlled down to the "shut down level" and an alarm is given. Reset by turning the rectifier $\rightarrow OFF \rightarrow ON$ or if the shut down level is higher than floating boost \rightarrow floating.

Adjustment:

- Disconnect the battery.
- Activate boost and adjust it to a higher level than the over voltage limit.
- Wait for alarm.
- Adjust the shutdown level possible from 0 to nearly 95% of UDCmax.
- Turn the boost down.
- $\rightarrow OFF \rightarrow ON$ and activate boost, adjust it and reconnect the battery.

Description ADC-II 300 & 600W (eng.)		Doc.no. MA0123	Rev.no. 7
Designed by Håkan Lundh	Approved by Hans Sterner	Page 14 of 22	Date 2001-06-29

4.3 Switches

The module (front) and 19" (rear) has four switches as follows:



Figure 8. Switch S1:1-4.

4.3.1 S1:1 Battery temperature compensation

UP=Battery temperature compensation, $-4\text{mV}/^\circ\text{C}$ and cell.

DOWN=No battery temperature compensation, default $+20^\circ\text{C}$.

If temperature compensation is used, a sensor $2\text{k}\Omega$ PTC must be connected to the X7A:3, 4 input and the switch must be in UP position.

Important: If no temperature compensation is needed and the switch is in DOWN position, then it is not allowed to have a sensor connected to the input. It could generate an alarm or give a wrong dangerous charging voltage level.

4.3.2 S1:2 Battery temperature thermal runaway alarm

UP=Battery temperature thermal runaway alarm.

DOWN=No battery temperature thermal runaway alarm, default.

The thermal runaway alarm is using the battery sensor to check the battery temperature. If the temperature reaches 40°C , the rectifier output is controlled down to the battery circuit test level and stays there until the battery temperature decreases down to 35°C . The common alarm is activated.

The battery temperature sensor has to be connected and S1:1=UP.

4.3.3 S1:3 Incorrect output voltage alarm

UP=Incorrect output voltage alarm.

DOWN=No incorrect output voltage alarm, default.

The actual output voltage is compared with the adjusted reference voltage and if the output moves away more than 2% up or down, the alarm is activated after a 5s time delay. The alarm is inhibited to work in boost and battery test mode. Then the operation LED is flashing on the module or rear side on the 19". In this case the rectifier has been charging batteries in boost mode and the rectifier has returned to floating but the voltage is kept high by the battery.

4.3.4 S1:4 Automatic boost with no option $\geq\text{CL}20$ (with option $\geq\text{CL}20$ see section 6.2.2)

UP=Automatic boost.

DOWN=No automatic boost, default.

The automatic boost switches the rectifier into boost level after a mains fault $>5\text{s}$. After the mains comes back the rectifier must run in power or current limit for $>30\text{s}$. When the output voltage reaches boost level, the rectifier returns automatic to the floating level.

Description ADC-II 300 & 600W (eng.)		Doc.no. MA0123	Rev.no. 7
Designed by Håkan Lundh	Approved by Hans Sterner	Page 15 of 22	Date 2001-06-29

4.4 Indications

There are four LEDs on the module and on the rear side of the 19" unit indicating:

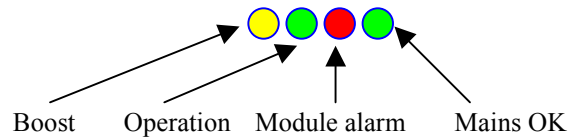

Figure 9. LEDs.

Yellow **XII** **Boost charge voltage.**

Green \odot **Operation.** Indication of running power converter, steady light.
Flashing LED means power converter stopped when the rectifier is running.
Normal behaviour after boost charge and the DC voltage is higher then floating level. This condition also blocks the DC over voltage protection circuit, if in parallel systems one of the rectifiers goes high on the output. When a common alarm LED is also active, an internal fault has occurred, see section 8 "Trouble shooting".

Red \llcorner **Module fault.** The rectifier has internal alarms with a 5-10s time delay. All alarms are connected to the common alarm relay output:

- Incorrect output voltage
- Thermal battery temperature runaway
- High DC-output voltage
- Battery sensor fault
- Rectifier fault (no control limit reached)
- High/low PFC voltage
- DC fuse failure
- High module temperature $>85^{\circ}\text{C}$

Green $\rightarrow \odot$ V **Mains available.** Indication of mains OK for operation. In parallel with mains alarm relay. OFF=alarm.

5. Maintenance

5.1 Maintenance

The float voltage level is recommended to be adjusted every two years to keep the correct charging voltage to the battery.

The fan has a long life time at high temperatures, so at normal conditions it doesn't need to be exchanged under the rectifier life time. At extreme conditions, full load and 40°C continuous operation, the fan needs to be exchanged every 3-4 years. Please contact our service dept. for detail information.

Description ADC-II 300 & 600W (eng.)		Doc.no. MA0123	Rev.no. 7
Designed by Håkan Lundh	Approved by Hans Sterner	Page 16 of 22	Date 2001-06-29

6. CL20 Front monitor (option)

6.1 Symbols on the front monitor

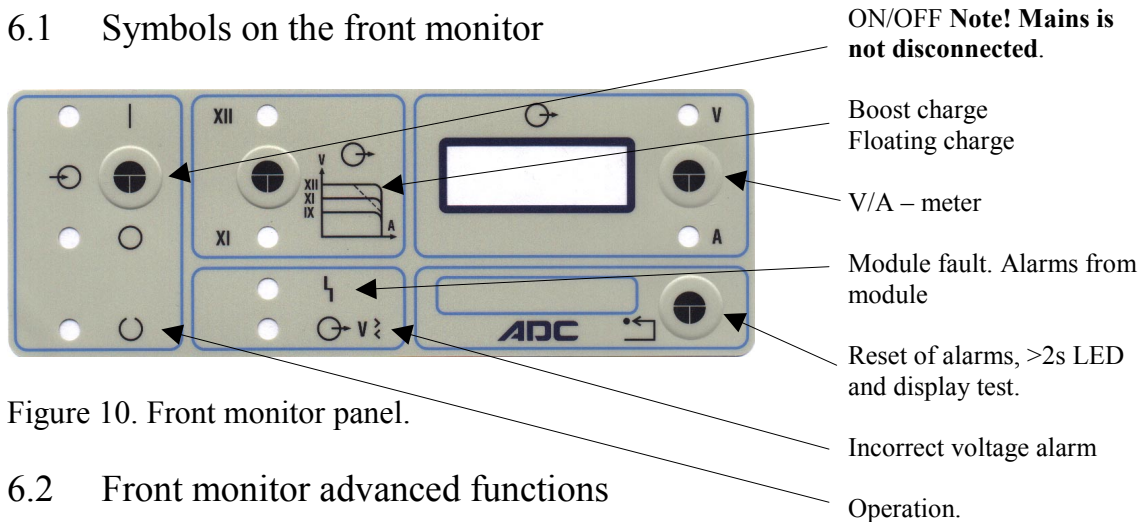

Figure 10. Front monitor panel.

6.2 Front monitor advanced functions

6.2.1 Common information.

Use with only front monitor board CL20, the buttons 'V/A' and 'Reset' behave like 'up' and 'down' arrows.

Reset button switches back to standard display.

6.2.2 Automatic boost charge times

- Press push buttons on/off and floating/boost for a time of >3s (until 'boost' is displayed).

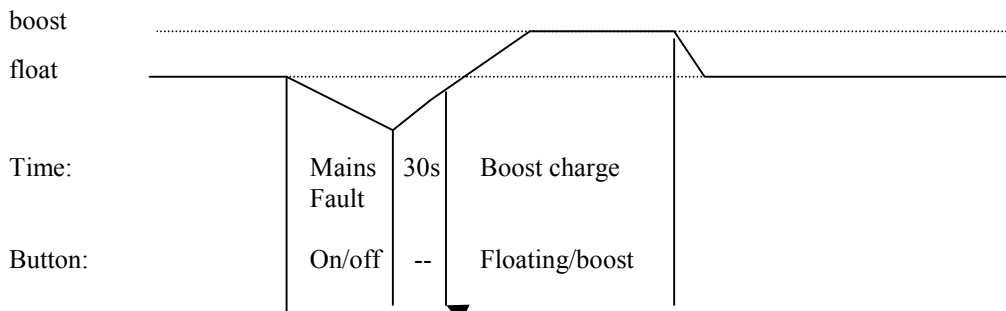

Figure 11. Automatic boost time schedule. If power or current limit is present at end of 30s fixed time delay, the boost starts.

If boost time is set to 0s, the automatic boost function is deactivated.

6.2.3 Manual boost charge time.

- Press push button float/boost for a time of >3s.

6.2.4 Adjusting levels for floating and boost.

- Switch module to the charging mode you want to change.

- Press push button on/off and the arrow-keys. For a short time the difference to nominal 0 in digits + or - is displayed, max ± 512 steps and then the adjusted voltage is displayed.

6.2.5 Displaying remaining time of boost charge.

- Press push buttons Boost and V/A. (If slave in parallel system, '-.- h' is displayed).

Description ADC-II 300 & 600W (eng.)		Doc.no. MA0123	Rev.no. 7
Designed by Håkan Lundh	Approved by Hans Sterner	Page 17 of 22	Date 2001-06-29

7. CL30 Alarm monitor (option)

7.1 Symbols on the alarm monitor

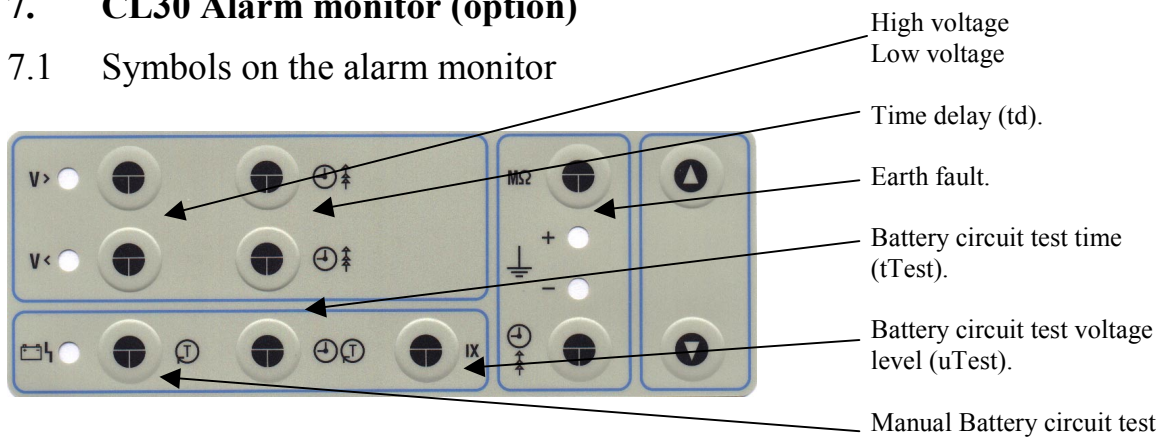

Figure 12. Alarm board panel.

7.2 Alarm monitor advanced functions

7.2.1 Common information: High, low and earth fault alarm

- Press a push button: Numerical information on 5 digit display. Change of value by arrow.
- Press push buttons for value and td at the same: Display hysteresis of each limit. Change of value by arrow.

7.2.2 Manual battery test

- Press, tTest displays/changes time of manual battery test.
- Press, uTest displays/changes alarm voltage level of manual test.
- Press, Manual Battery test starts directly a manual test.
- Press, Manual Battery test again stops the test.

7.2.3 Automatic battery test

- Press push buttons tTest and uTest for a time of >3s, until 'Auto' is displayed.
- Press, tTest displays/changes time of automatic battery test.
- Press, uTest displays/changes alarm voltage level.
- Press, Manual Battery test displays/changes interval of automatic battery test, shown as: xxday/xxmon/xx yr/xx h/xxMin. If interval-time is=0, no automatic battery test is started!
- Press, V/A shows time left until next automatic battery test ('-.-' if it is just changed).
- Press, Reset button switches back to standard display.

7.2.4 Displaying time and voltage of last/current battery test

- Press push button BatteryTest for a time of >3s. With the arrow-keys, you can display the time and voltage of the last/running battery test. These values are updated in manual battery test or if the automatic battery test time is >60s.

7.2.5 Adjusting the battery circuit test level.

- Switch the module to manual battery circuit test, see 7.2.2.
- Press push button on/off and the arrow-keys. For a short time the difference to nominal 0 in digits + or - is displayed, max ± 512 steps and then the adjusted voltage is displayed.



7.2.6 Displaying present earth-resistance ($M\Omega$)

- Press push buttons $M\Omega$ and V/A at the same time.

Description ADC-II 300 & 600W (eng.)		Doc.no. MA0123	Rev.no. 7
Designed by Håkan Lundh	Approved by Hans Sterner	Page 18 of 22	Date 2001-06-29

8. Trouble shooting

The interesting alarm is the module alarm, the red LED on the module, rear side of the 19" unit or if the front panel option is used the red LED  on the front lights, to detect problems in the rectifier.

Failure indication	Cause of failure	Measure
The module fault LED is "ON" on the module or on the front panel, CL20, or the incorrect voltage alarm LED on the front panel, CL20, is "ON" and the common alarm relay is fallen.	1. The rectifier is delivering power to the DC output close to the floating level.	If the DC-voltage differs more than $\pm 2\%$ from adjusted voltage an incorrect alarm is given. Check that the load is not too high. Switch off the alarm function by S1:3 down and then up again.
	2. The battery temperature is $< -20^{\circ}\text{C}$ or $> +70^{\circ}\text{C}$ not correct.	If the battery temperature is normal, the sensor can be shorted or disconnected. Check the sensor at the input X7A:3, 4. Check the switch S1:1 position UP if battery compensation is used. Check that if no sensor is connected to the input X7A:3, 4 the switch S1:1 is in position DOWN.
	3. DC over voltage.	The protection circuit detected a high voltage for $> 2\text{s}$ on the DC output. Try to reset the alarm by turning the rectifier "ON/OFF". If the fault disappears, the high voltage could be something temporary from DC load. If the fault returns check the output voltage of the rectifier and adjust the potentiometer "shut down" level a bit (normally adjusted to 2.3V/cell) on the module to verify if it is this alarm who is active now.
	4. The rectifier is running at a low output voltage. Thermal runaway.	Check the battery temperature. If the battery temperature is $> 38-40^{\circ}\text{C}$, hysteresis down to 35°C , this alarm, if activated by S1:2 UP, is controlling the rectifier to battery circuit test level and an alarm is given. Check it by remove the alarm by turning S1:2 DOWN temporary.
	5. No regulation limit active.	Check if mains is available. Green LED  V on the module or on the rear side of the 19" is "ON". Also check if the circuit breaker or the DC fuse on the module or on the rear side of the 19" is tripped or broken. If all above is OK then a major fault has occurred. Please contact the service department.
	6. High temperature	If the fan doesn't work at high ambient temperature and high load the rectifier can be overheated and the alarm acts to reduce output power and alarm is given. Please check the fan if operate, see functional description part 4.
	7. No DC current on the output.	Check if mains is available. Green LED  V on the module or on the rear side of the 19" is "ON". Also check if the circuit breaker or the DC fuse on the module or on the rear side of the 19" is tripped or broken.
The module fault LED is "OFF" on the module or on the rear side of the 19" (relay fallen) and the rectifier fault LED on the front is "ON".	1. The rectifier is not running.	Check if mains is available. Check the operation and mains available LEDs on the module or the rear side of the 19".
	2. The internal supply not working.	Please contact the service department.
Both the rectifier fault LEDs are "OFF" (relay fallen).	1. No DC current on the output.	Check if mains is available. Green LED  V on the module or on the rear side of the 19" is "ON". Also check if the circuit breaker or the DC fuse on the module or on the rear side of the 19" is tripped or broken.

Service department at Eldaco AB:

Tel: +46(0)8 623 95 00, Fax: +46(0)8 96 97 72, Email: power@eldaco.se

Description ADC-II 300 & 600W (eng.)		Doc.no. MA0123	Rev.no. 7
Designed by Håkan Lundh	Approved by Hans Sterner	Page 19 of 22	Date 2001-06-29

9. Technical data

Input

Voltage range	230V AC $\pm 15\%$
Frequency	47-63Hz, 1-phase
Current	Max 2.2A (300W) and 4A (600W) at 195V AC
Efficiency	82-90%, depending on model, at 230V AC and max power on the output
Power factor	>0.98 at 230V AC and max power on the output
Protection	Fuse 4AT (300W) and 6.25AT (600W) 5 \times 20mm, reachable from the outside of the module
Soft start	Max 2s delay + 30s slow start with option CL20-40
Inrush current limit	Max 10 \times mains fuse (40 and 62.5A)
Cable entry AC terminal module	2.5mm ²
Cable entry AC terminal 19"	Plug in IEC 320 std.

Output

Constant voltage rectifier with power and current limit:

DC voltage nom. (V)	12	24	24	48	48	60	60	110
Output power max.(W)	300	320	600	320	650	320	650	620
DC current nom. (A)	20	12	20	6	12	4.8	9.5	5
DC current max. (A)	20	15	20	7.5	15	6	12	6.4
Lead cells	6	12	12	24	24	30	30	53, 54, 55

Voltage adjustment	Three independent different levels: Floating: 2.0-2.35V/cell Boost: 2.3-2.5V/cell Battery circuit test range: 1.8-1.9V/cell
Incorrect voltage alarm	Alarm level: $\pm 2\%$ of adjusted float voltage, not adjustable. Time delay: 5s, not adjustable.
Current limit	75% of DC current max - DC current max +2 %
Static voltage regulation	$<0.5\%$ adjustable with voltage drop compensation
Static current regulation	$\pm 1\%$
Short circuit proof	Yes
Reversed battery protection	Circuit breaker 25A ≤ 60 VDC and fuse 10A 110VDC rec.
Transient response	Load step 10-90-10 % without battery $\pm 8\%$ recovery 5-10ms
Ripple	0.05% RMS of Unom
Noise	1 % peek to peek of adjusted voltage (BWL: 30MHz)
Psofometric voltage	1mV for 12 and 24V 2mV for 48 and 60V
Output voltage drop compensation	-1.5% - +4% at min - max load

Description ADC-II 300 & 600W (eng.)		Doc.no. MA0123	Rev.no. 7
Designed by Håkan Lundh	Approved by Hans Sterner	Page 20 of 22	Date 2001-06-29

DC over voltage protection	Protection level: 2.4-2.6V/cell time delay: 1-2s shut down level: 0-94% of over voltage protection limit
Battery temperature compensation	-3.3 to -4.2 mV/ °C /cell
Temp. comp. range	-20°C to + 70°C
Temp. comp. alarm levels	<-20°C and >+70°C
Thermal runaway	38-42°C, hysteresis 3-6°C
Temperature sensor	KTY 81-210 (2kΩ PTC at 25°C)
Hold up time	10ms
Parallel operation	Passive current sharing ±20% of Inom
Alarm relays	DC: 150V, 2A, max 60W, AC: 250V, 2A, 62,5VA
Cable entry signal	1.5 mm ²
Cable entry DC output	10 mm ²

Options

CL20 front monitor	Digital voltage and amperemeter LCD 4 digit ±2% of nominal DC output
--------------------	---

Boost charge	Mains fault delay	Start delay	Time range
Manual	---	---	0s-16h 39min
Automatic	0s-16h 39min	30s fixed	0s-16h 39min

CL30 alarm monitor

Alarms	Alarm level	Time delay	Hysteresis
High and low voltage	0-1.5×Unom	0s-16h 39min	0-1.5×Unom
Earth fault +/-	0kΩ-1.0MΩ	0s-16h 39min	0kΩ-1.0MΩ

Alarms	Alarm level	Test time range	Automatic interval time
Battery circuit test manual	0-1.5×Unom	0s-16h 39min	--
Battery circuit test automatic	0-1.5×Unom	0s-16h 39min	yy-mm-dd-hh-mm

Alarm levels tol.	±2% of Unom, earth fault ±30kΩ
CL40 relay board	5 alarm relays max data: DC: 300V, 8A, max 100W voltage dependent AC: 300V, 8A, max 2000W
DC/DC	Output 9 - 10V, max load 5W (attached option boards).

Description ADC-II 300 & 600W (eng.)		Doc.no. MA0123	Rev.no. 7
Designed by Håkan Lundh	Approved by Hans Sterner	Page 21 of 22	Date 2001-06-29

Dimensions and weight

	Module	19"	Wall-mounted
Width (mm)	250	19"	275
Height (mm)	190	88	410
Depth (mm)	170	240	190
Weight approx.(kg)	6	6	10

General

MTBF	60.000h
Enclosing	IP20
Noise	max 40dB(A) at 1m with fan in operation max 55dB(A) at 1m.

Environmental

Operation temperature	module and 19": 0°C to +50° wall: 0°C to +40°
Storage temperature	-40°C to + 85°C
Altitude	max 1000m above sea level. For higher altitudes reduce output power by -10%/1000m
Humidity	0 % to 95 % Rh non condense

Fan data

Operation life time	min 25000h at +40°C ambient.
Type	Innovative BP802524H 24V 0.13A or equivalent.
Part no:	737069

Description ADC-II 300 & 600W (eng.)		Doc.no. MA0123	Rev.no. 7
Designed by Håkan Lundh	Approved by Hans Sterner	Page 22 of 22	Date 2001-06-29

10 Default settings

Cell is equal to lead acid battery cell.

Potentiometer settings:

Unom	Cells	Floating 2.23V/cell	Boost 2.4V/cell	Bat. circ. Test. 1.8V/cell	Current limit	Output drop -0.2%	Shutdown 2.3V/cell
12V	6	13.4V	14.4V	10.8V	20.3A (300W)	25mV	13.8V
24V	12	26.8V	28.8V	21.6V	15.3A (300W) 20.3A (600W)	50mV	27.6V
48V	24	53.5V	57.6V	43.2V	7.6A (300W) 15.3A (600W)	100mV	55.2V
60V	30	66.9V	72V	54V	6.2A (300W) 12.2A (600W)	135mV	69V
110V	54	120.4V	129.6V	97.2V	6.5A (600W)	240mV	124.2V

Settings on front monitor CL20:

Manual boost charging time	5h
Automatic boost mainsfail delay time	10s
Automatic boost charging time	5h

Settings on alarm monitor CL30:

Unom	Cells	Low voltage alarm 1.9V/cell	High voltage alarm 2.33V/cell	Delay	Hyst.
12V	6	11.4 V	14.0 V	10s	0.1V
24V	12	22.8 V	28.0 V	10s	0.1V
48V	24	45.6 V	55.9 V	10s	0.2V
60V	30	57.0 V	69.9V	10s	0.3V
110V	54	102.6 V	125.8 V	10s	0.5V

Unom	Bat. circ. alarm level manual and automatic 1.96V/cell	Manual Test time	Automatic Test time	Automatic interval time
12V	11.8 V	1 hour	10s	1day
24V	23.5 V	1 hour	10s	1day
48V	47.0 V	1 hour	10s	1day
60V	58.8 V	1 hour	10s	1day
110V	105.8 V	1 hour	10s	1day

Alarms	Unom	Alarm level	Time range	Hysteresis
Earth fault +/-	12-110V	500k Ω	10s	10k Ω

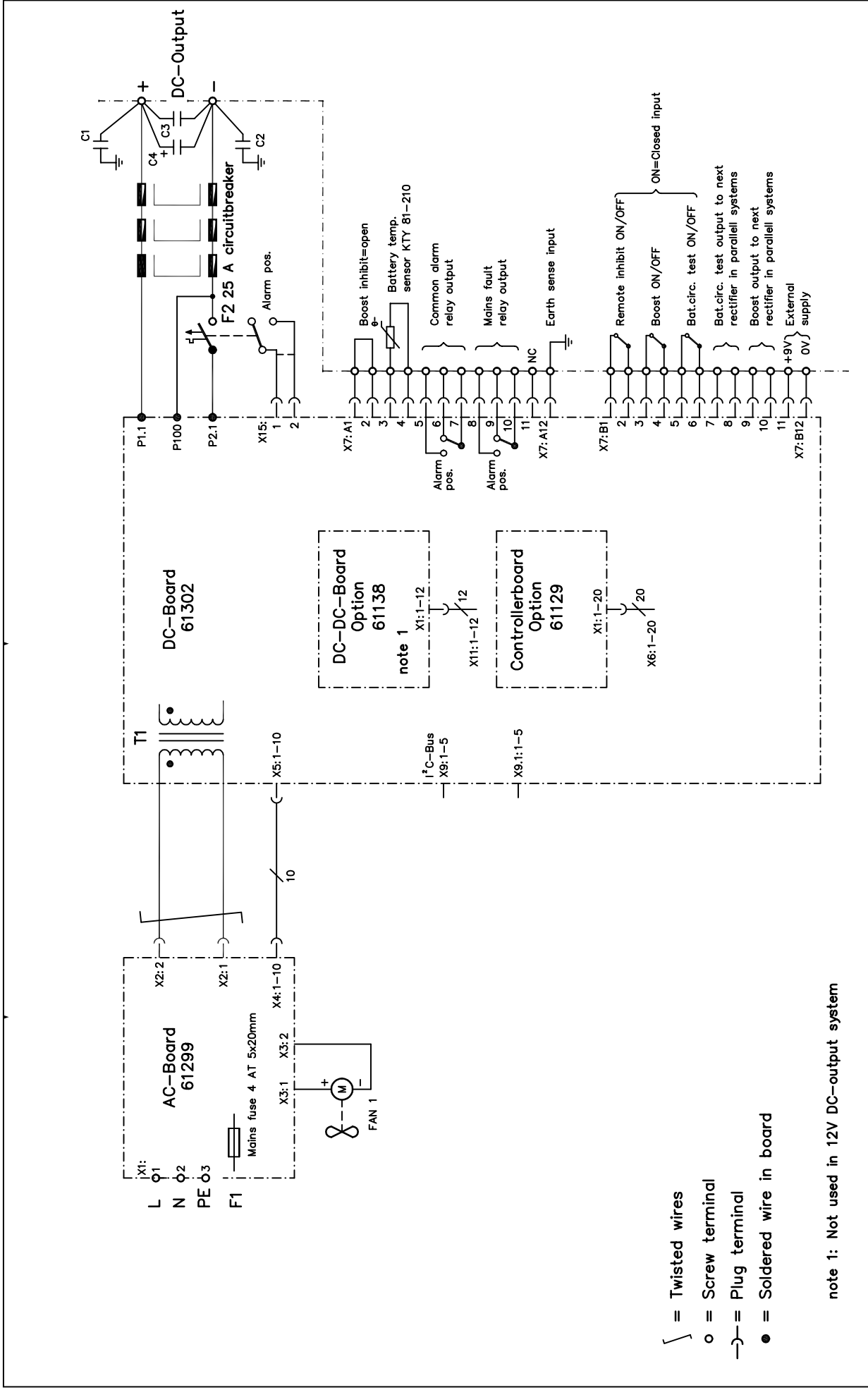

- = Twisted wires
- = Screw terminal
- = Plug terminal
- = Soldered wire in board

note 1: Not used in 12V DC-output system

Dwg.-No	Pcs.	Denomination	Material	Dimension	Art.No: C11202
Constr.by: Date: J.H.000407	Drawn by: Date: H.L.000411	Approved by: M.M.	Scale:	Replaces Rev.1	Tolerances:
				Rev.No: 2	Revised Date: J.H. 010305
ADC II 300W MODULE				Drawing No: 3E 10865	



No Pcs.	Revision and / or notification no.	Date	Int.	Appr.

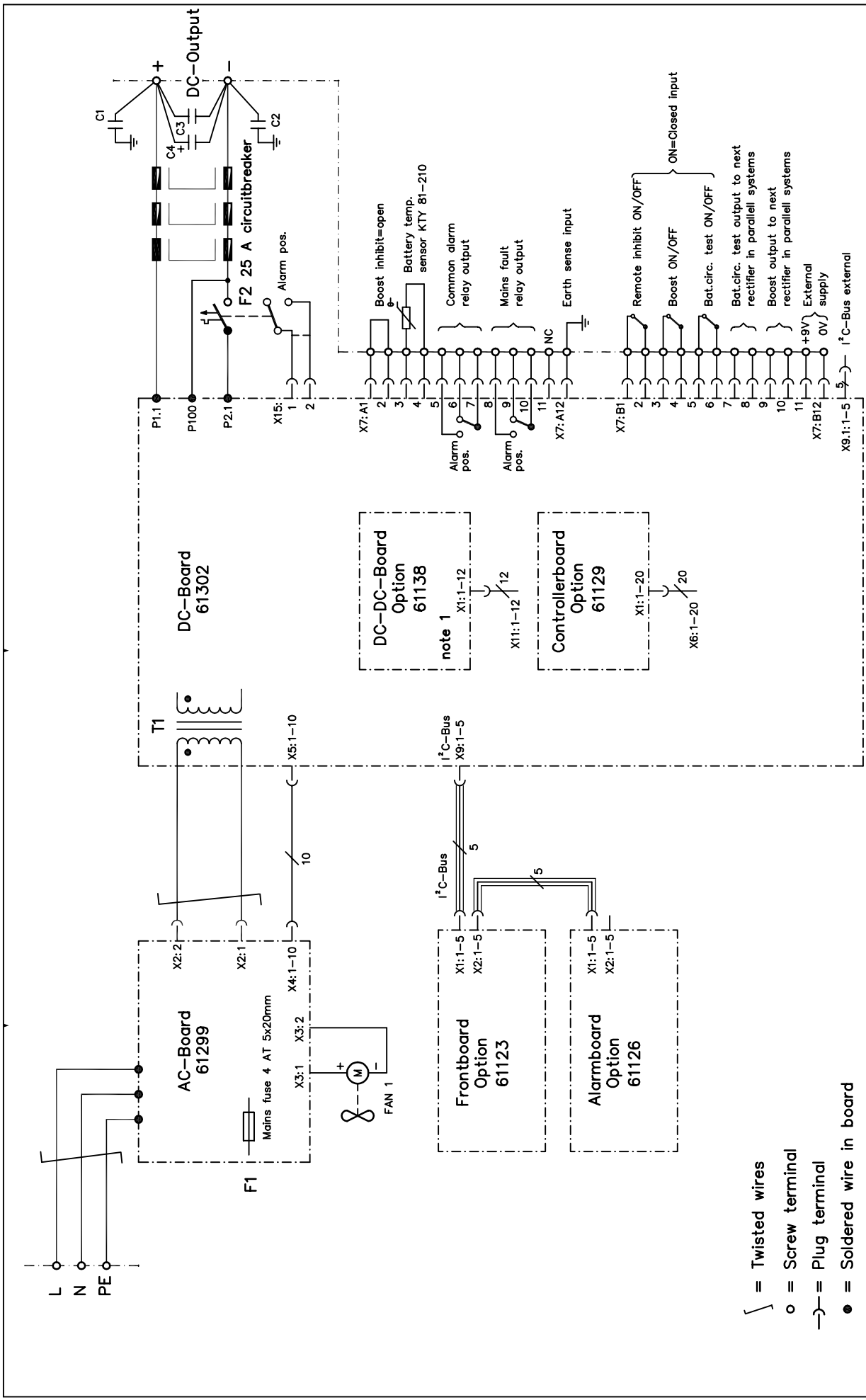

note 1: Not used in 12V DC-output system

- ∩ = Twisted wires
- = Screw terminal
- = Plug terminal
- = Soldered wire in board

Dwg.-No	Pcs.	Denomination	Material	Dimension	Art.No:
Constr.by: J.H.000407	Date: H.L.000411	Approved by: M.M.			C11203
Replaces REV.0			Tolerances:		
Rev.No: 1			Revised by: REV.0		
Date: 010305			Replaced by:		
Drawing No: 3E 10866			ADC II 300W 19"		



No Pcs.	Revision and / or notification no.	Date	Inf.	Appr.	Date	Inf.	Appr.
---------	------------------------------------	------	------	-------	------	------	-------

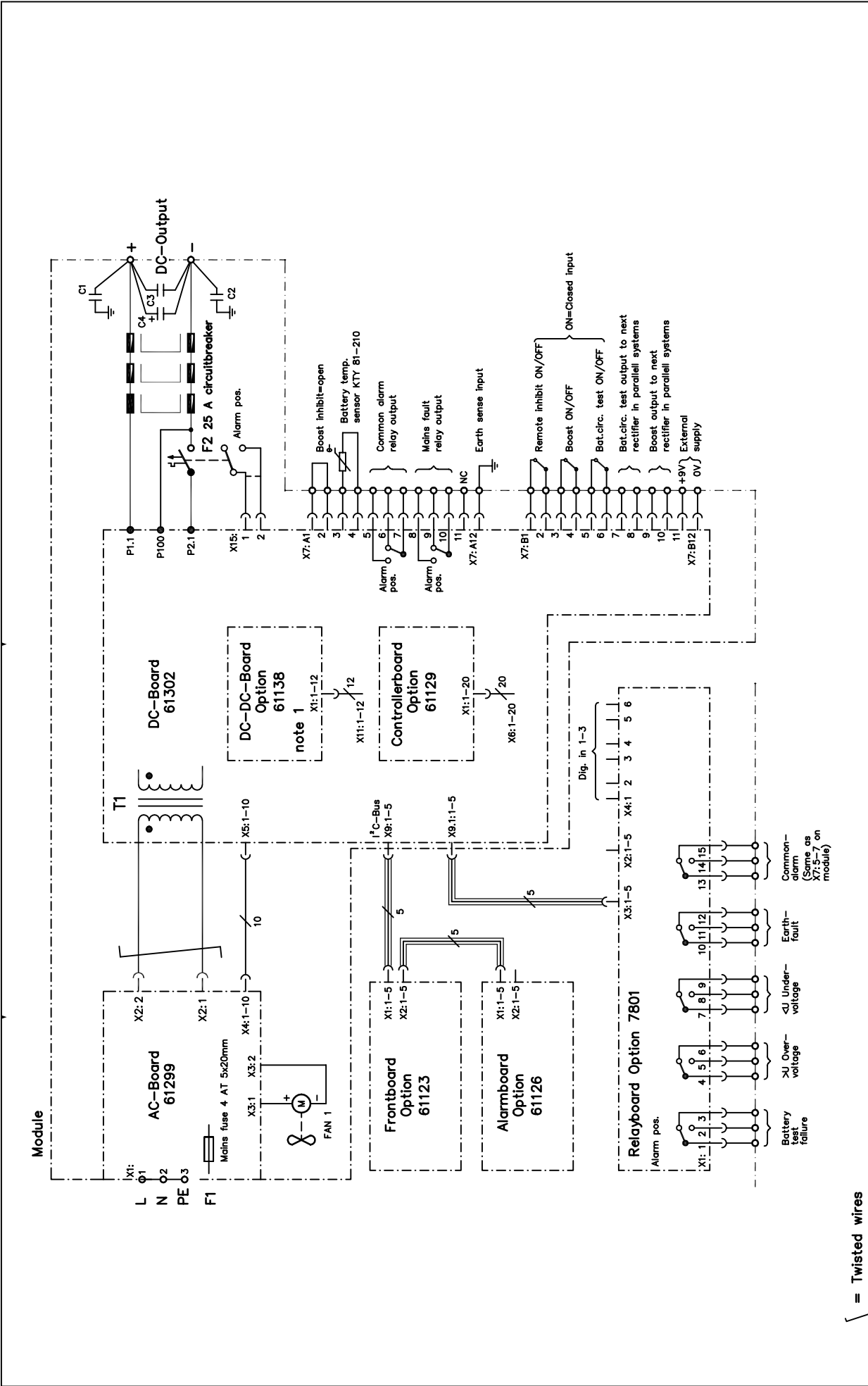

- = Twisted wires
- = Screw terminal
- = Plug terminal
- = Soldered wire in board

note 1: Not used in 12V DC-output system

note 1: Soldered wire in board

Dwg.-No	Pcs.	Denomination	Material	Dimension	Art.No: C11204
Constr.by: Date: J.H.000407	Drawn by: Date: H.L.000411	Approved by: M.M.	Scale:	Replaces REV.0	Tolerances:
				Rev.No: 1	Revised by: Date: J.H. 010305
					Drawing No: 3E 10867



ADC II 300W WALL

No Pcs.	Revision and / or notification no.	Date	Inf.	Appr.	Date	Inf.	Appr.
---------	------------------------------------	------	------	-------	------	------	-------

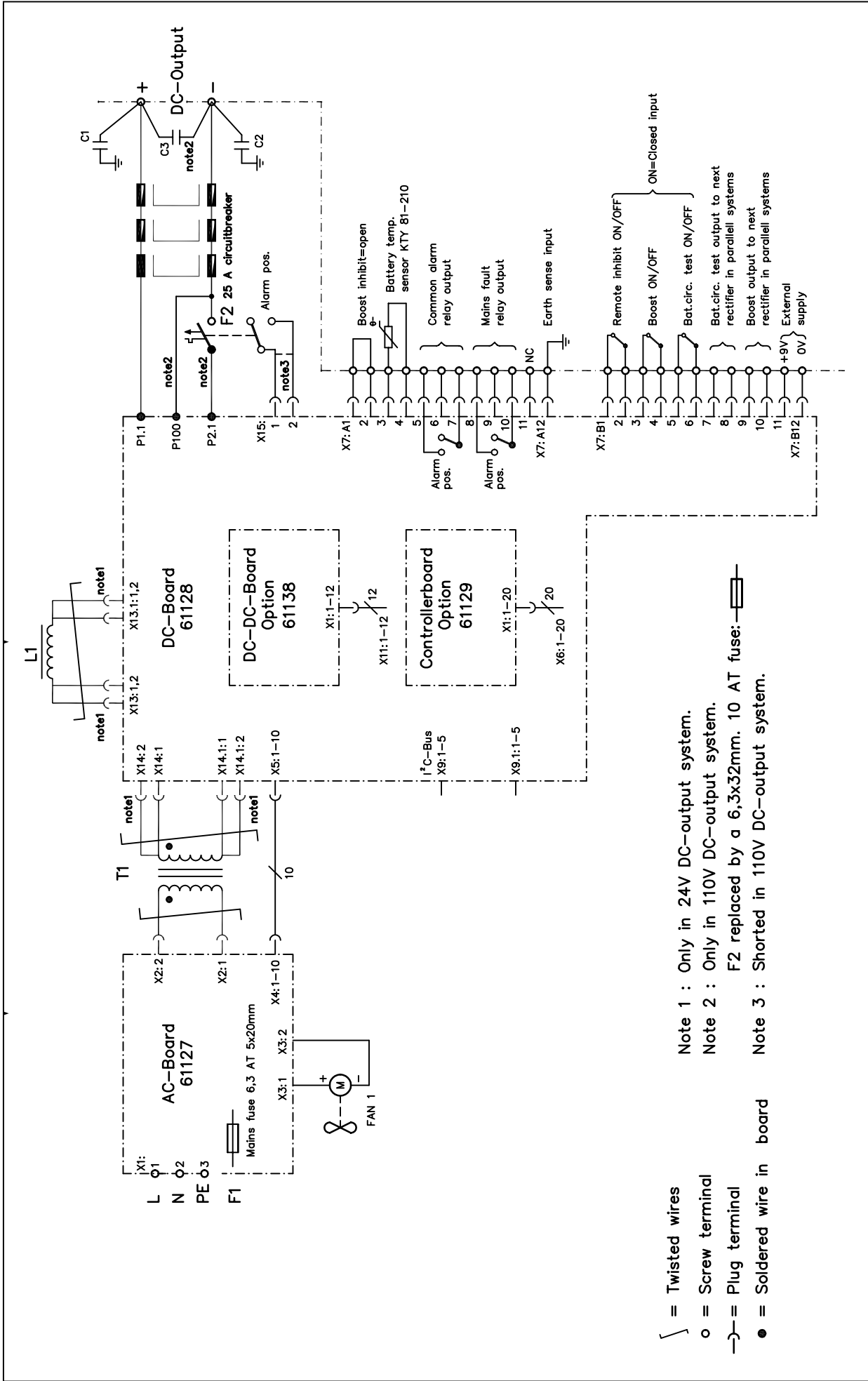

- = Twisted wires
- o = Screw terminal
- o— = Plug terminal
- = Soldered wire in board

Note 1 : Only in 24V DC-output system.
 Note 2 : Only in 110V DC-output system.
 F2 replaced by a 6,3x32mm, 10 AT fuse:
 Note 3 : Shorted in 110V DC-output system.

Dwg.-No	Pcs.	Denomination	Material	Dimension	Art.No: 11577
Constr.by: Date: M.M.990224	Drawn by: Date: M.A.990301	Approved by: M.M.		Replaces REV.0	Tolerances:
				Rev.No: 1	Replaced by
				Rev/By: J.H	Date: 010305
ADC II 600W MODULE			3E 10379		



No Pcs.	Revision and / or notification no.	Date	Inf.	Appr.	No Pcs.	Revision and / or notification no.	Date	Inf.	Appr.
---------	------------------------------------	------	------	-------	---------	------------------------------------	------	------	-------

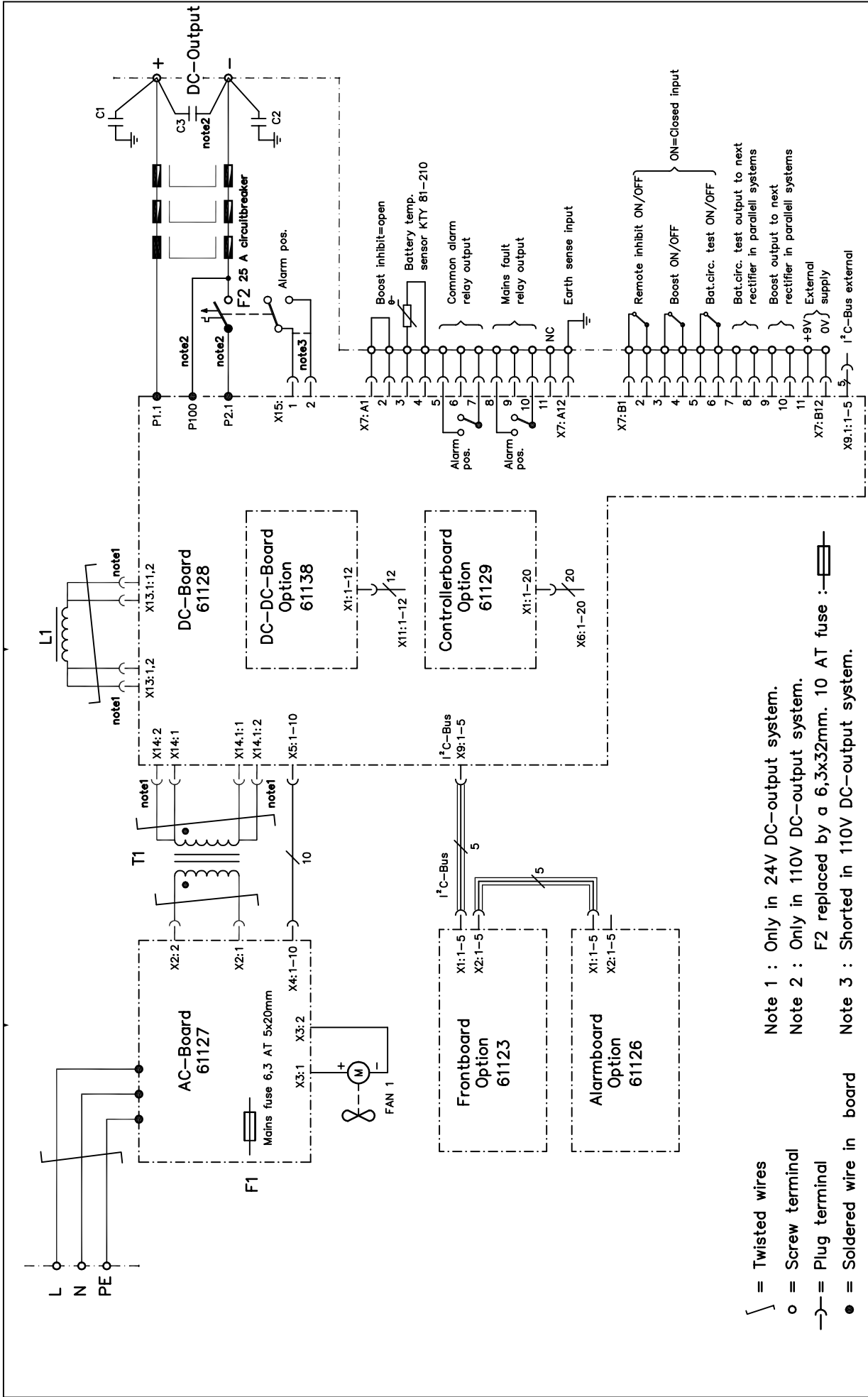

- ∩ = Twisted wires
- o = Screw terminal
- = Plug terminal
- = Soldered wire in board

- Note 1 : Only in 24V DC-output system.
- Note 2 : Only in 110V DC-output system.
- Note 3 : Shorted in 110V DC-output system.

Dwg.-No	Pcs.	Denomination	Material	Dimension	Art.No:
Constr.by: M.M.990224	Drawn by: M.A.990301	Approved by: M.M.			11578
Tolerances:			Replaces: REV.1		
Replaced by:			Rev.No: 2		
Date:			Rev/By: J.H. 010305		
Drawing No:			3E 10377		
ADC II 600W 19"					

No Pcs.	Revision and / or notification no.	Date	Inf.	Appr.

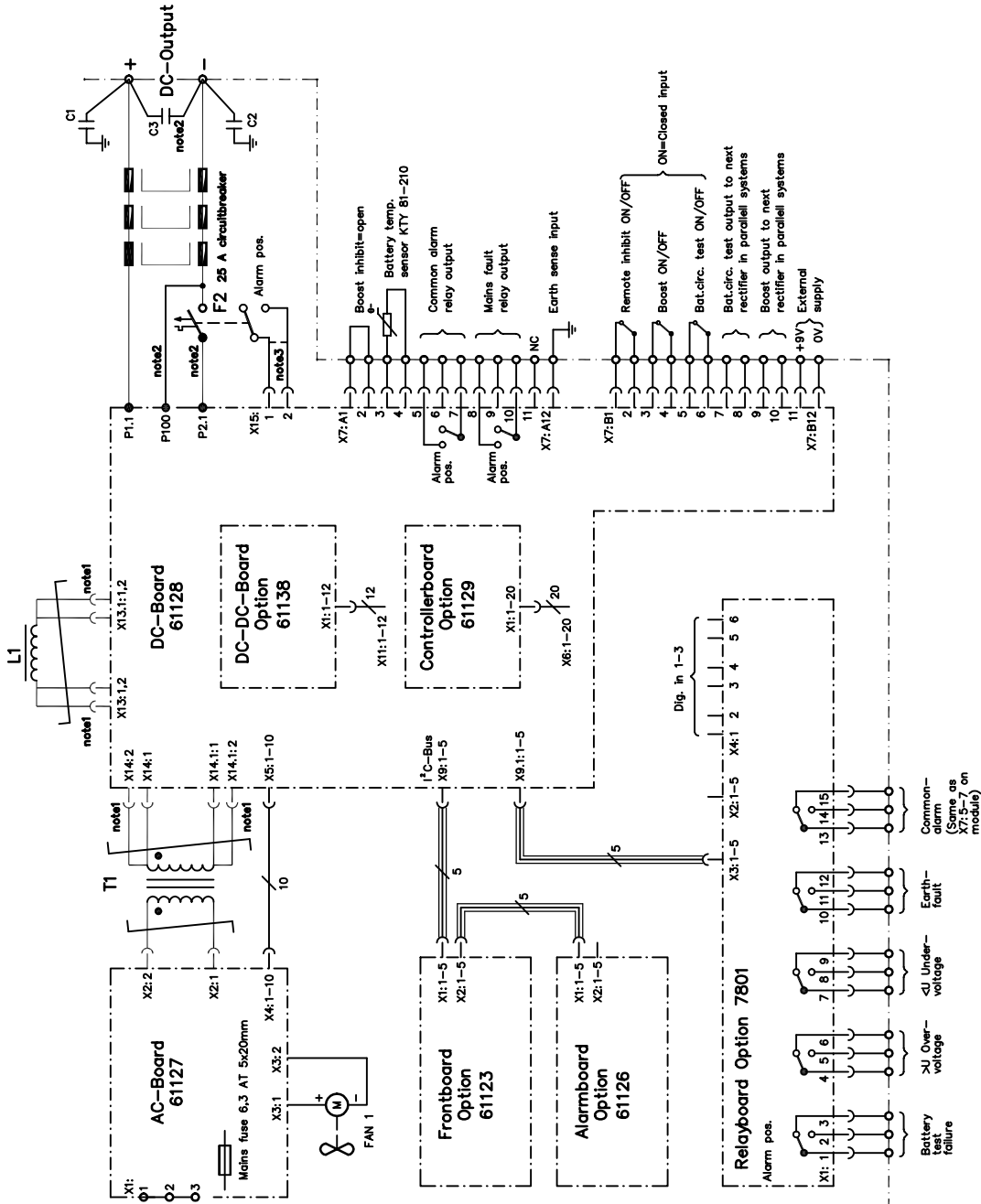

- = Twisted wires
 - o = Screw terminal
 - = Plug terminal
 - = Soldered wire in board
- Note 1 :** Only in 24V DC-output system.
Note 2 : Only in 110V DC-output system.
F2 replaced by a 6.3x32mm, 10 AT fuse:
- Note 3 :** Shorted in 110V DC-output system.

Dwg.-No	Pcs.	Denomination	Material	Dimension	Art.No: C10292
Constr.by: M.M.990224	Date: M.A.990301	Drawn by: M.A.990301	Approved by: M.M.	Scale:	Tolerances:
					Replaces Rev.1
					Replaced by Rev.2
					Rev.No: 2
					Rev/By: J.H 010305
					Drawing No: 3E 10603
			ADC II 600W WALL		

No Pcs.	Revision and / or notification no.	Date	Inf.	Appr.
No Pcs.	Revision and / or notification no.	Date	Inf.	Appr.